

REVISIONS				
ZONE	LTR	DESCRIPTION	DATE	APPROVED

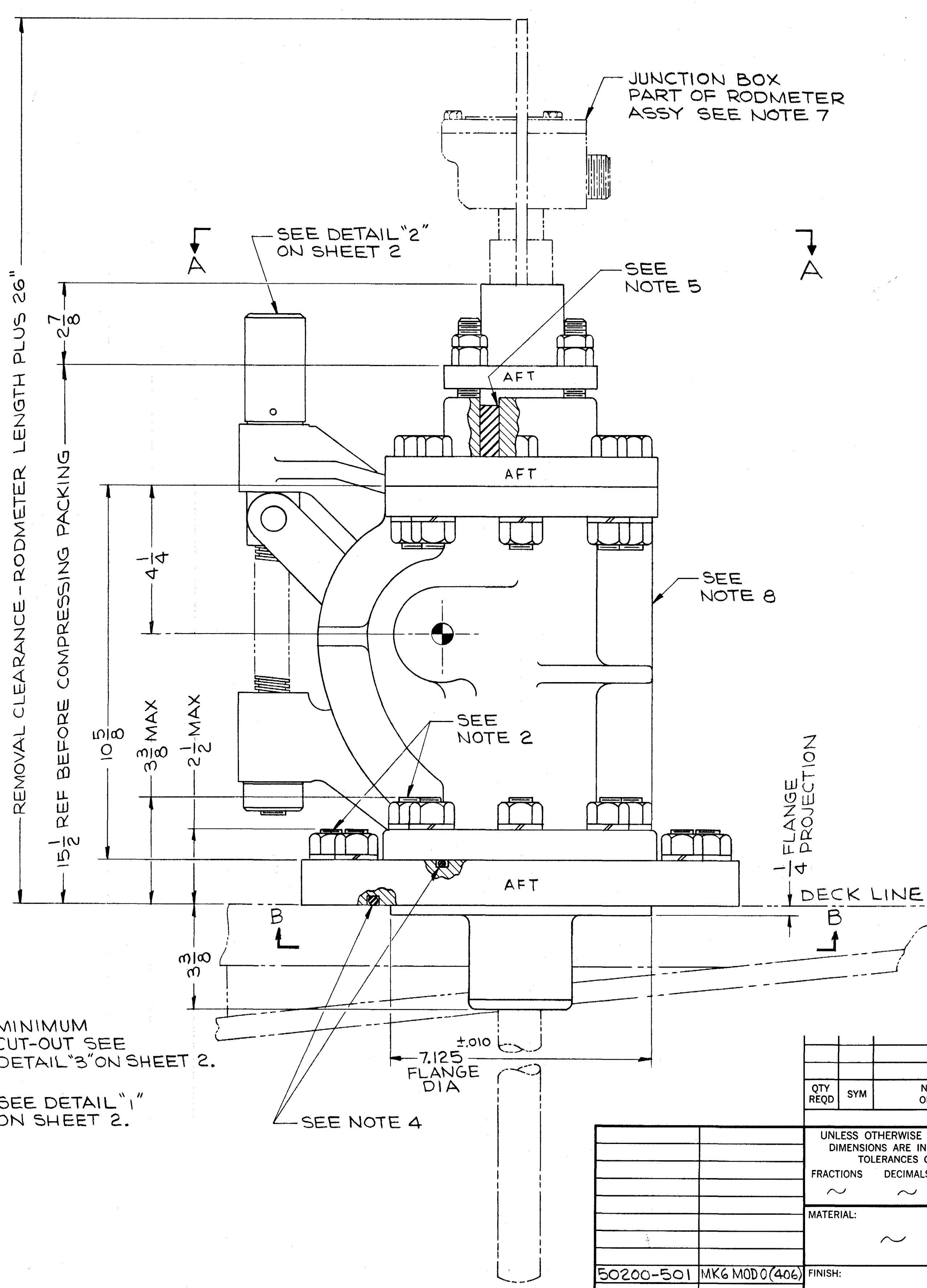
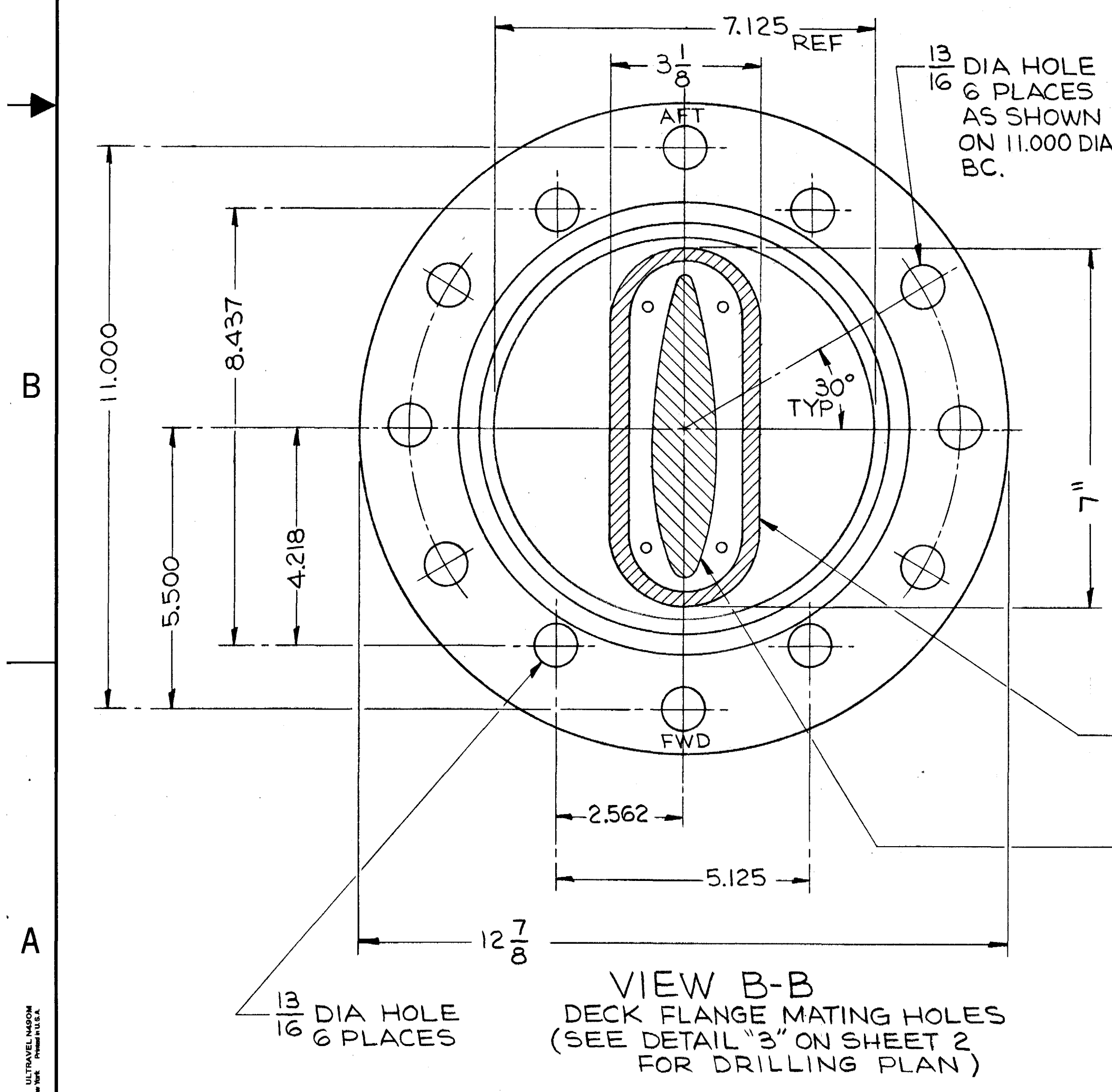
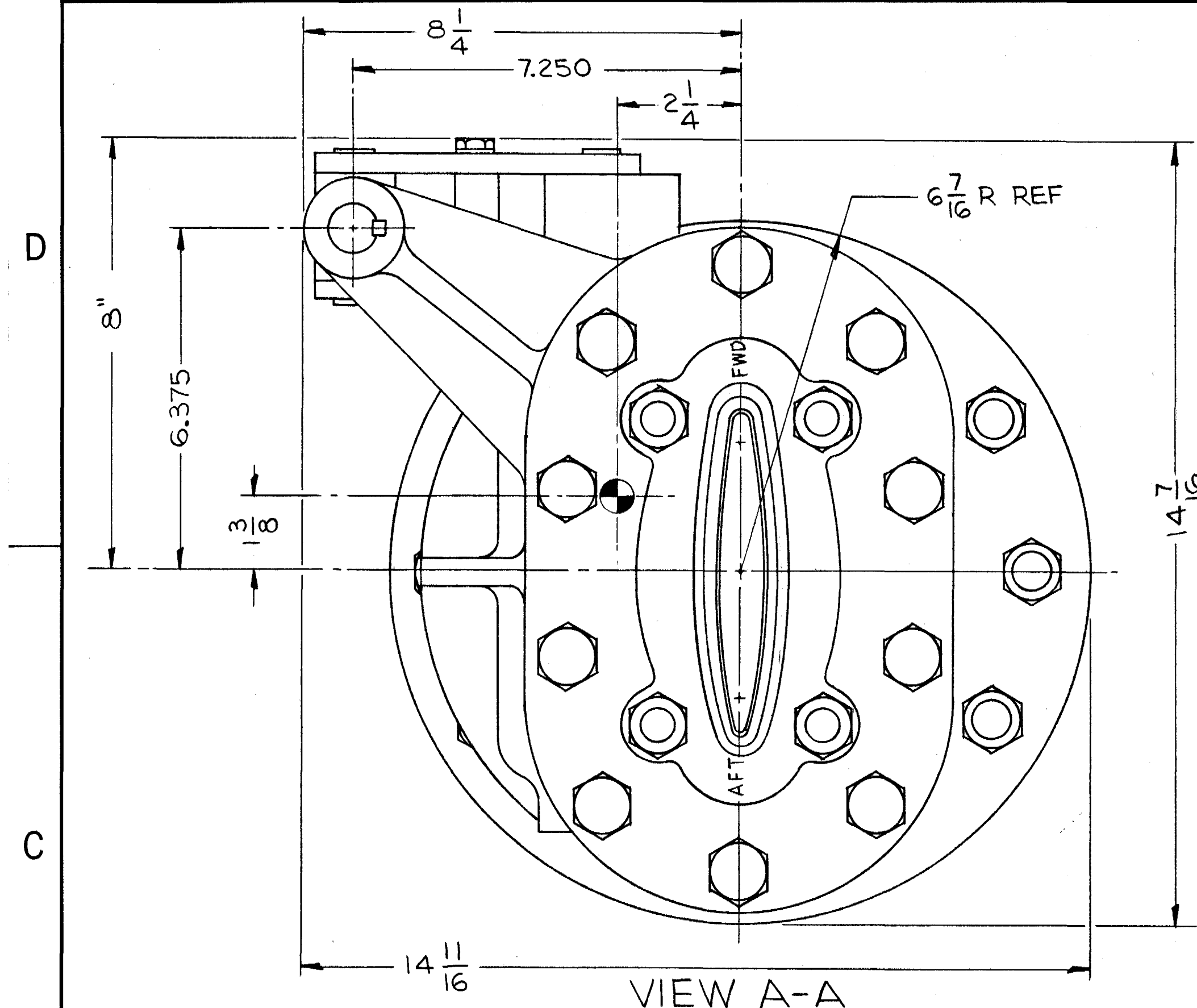

- NOTES:
- MATERIAL IS NICKEL ALUMINUM BRONZE CASTING PER MIL-B-23921.
 - INSTALLING ACTIVITY SHALL SUPPLY THE FOLLOWING HARDWARE FOR MOUNTING SEA VALVE & PACKING ASSY:
 12 HEX NUTS 3/4-10NC-2 NI-COP ALLOY
 6 STUDS 3/4-10NC-2 x 3 1/2 LG NI-COP ALLOY
 6 STUDS 3/4-10NC-2 x 4 1/2 LG NI-COP ALLOY
 12 LOCK WASHERS, SPRING # 3/4 NI-COP ALLOY
 1 MACHINED DECK PLATE NI-COP ALLOY
 - ⊙ DENOTES CENTER OF GRAVITY.
 - "O" RINGS ARE SUPPLIED BY CONTRACTOR. GROOVES ARE COATED WITH SILICONE COMPOUND PER MIL-S-8660.
 - BEFORE INSERTING RODMETER ASSY, LUBRICATE ROD & PACKING WITH ORDINARY BAR SOAP PER P-S-591.
 - APPROXIMATELY 22 TURNS OF THE DRIVE SCREW ARE REQUIRED TO OPEN OR CLOSE SEA VALVE.
 - JUNCTION BOX MAY BE INSTALLED ON RODMETER IN FOUR POSITIONS: ONE AS SHOWN OR ROTATED IN 90° STEPS UP TO 360°.
 - VALVE BODY MAY BE INSTALLED ON DECK FLANGE IN TWO POSITIONS: ONE AS SHOWN OR ROTATED 180°.
 - WEIGHT = 200 LB
CRATED WEIGHT = 220 LB
 - OVERALL CRATED DIM. = 26" x 24" x 24"
 - CUBICAL CONTENT = 2.6 CU FT
CRATED CUBICAL CONTENT = 9.4 CU FT
 - SURFACE LOAD BEARING = 2.44 PSI
 - THIS EQUIPMENT IS IN ACCORDANCE WITH MIL-U-18033 F W/AMEND 2.

REFERENCES:
1. DRAWING LIST-SEE DWG 30643.

QTY REQD	SYM	NOMENCLATURE OR DESCRIPTION	CODE IDENT	PART OR IDENTIFYING NO.	SPECIFICATION	MATERIAL OR NOTE	UNIT WT	ZONE	ITEM NO.
LIST OF MATERIALS OR PARTS LIST									
UNLESS OTHERWISE SPECIFIED DIMENSIONS ARE IN INCHES TOLERANCES ON FRACTIONS DECIMALS ANGLES					DRAWING STARTED DATE		PITOMETER LOG CORP PARAMUS, N.J.		
DRAWN <i>Vincent & Giunta</i> 12 AUG 74					CHECKED		SEA VALVE SV-(C) MK6 MOD 0 EM LOG OUTLINE & INSTALLATION DRAWING		
MATERIAL:					ENGR		SIZE CODE IDENT NO.		
50200-501 MK6 MOD 0 (406)					FINISH:		D 47496		50225
NEXT ASSY USED ON					APPLICATION		SCALE 1/2		SHEET 1 OF 2

ULTIMATE NADIM

50225

REVISIONS				
ZONE	LTR	DESCRIPTION	DATE	APPROVED

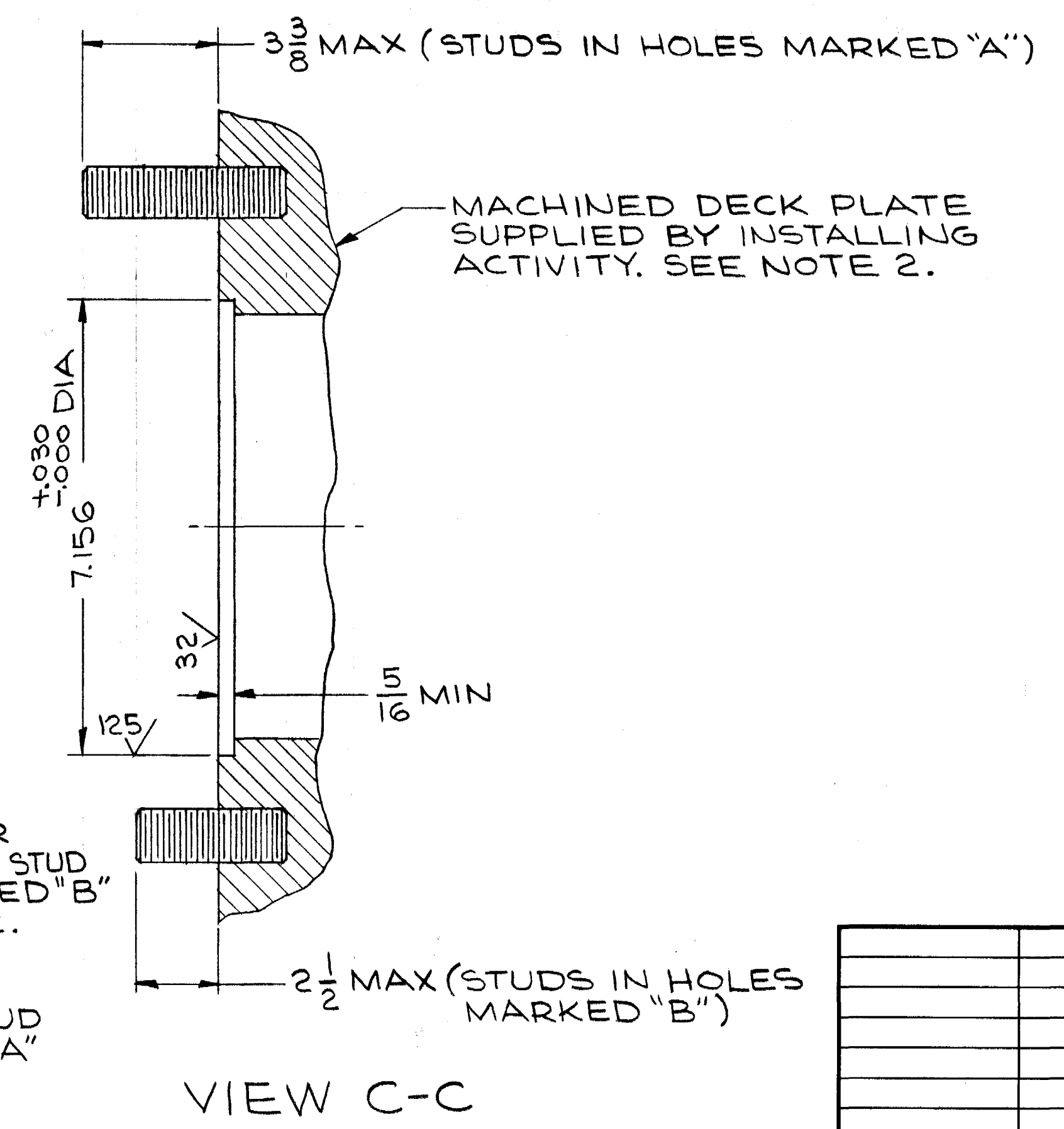
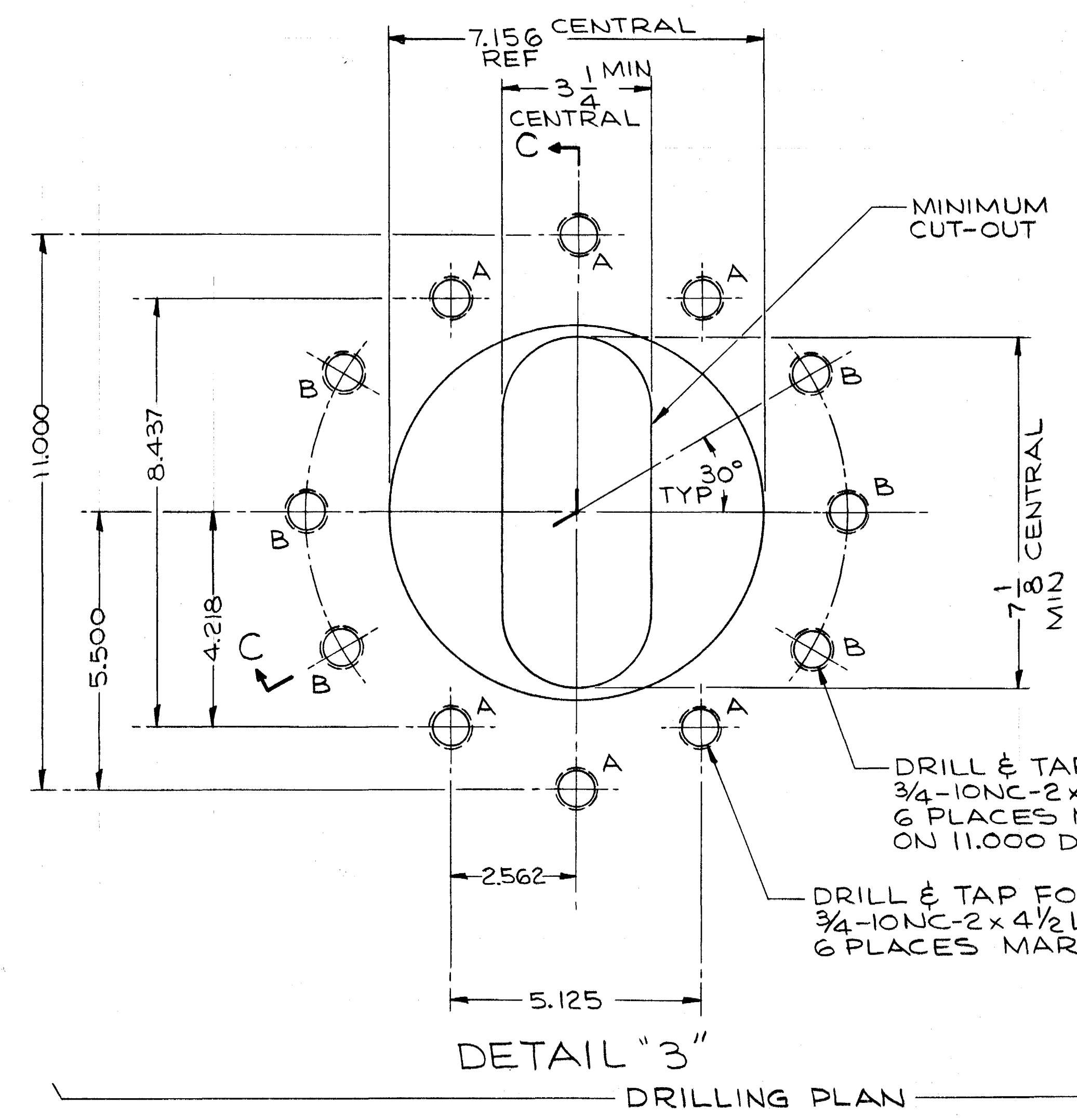
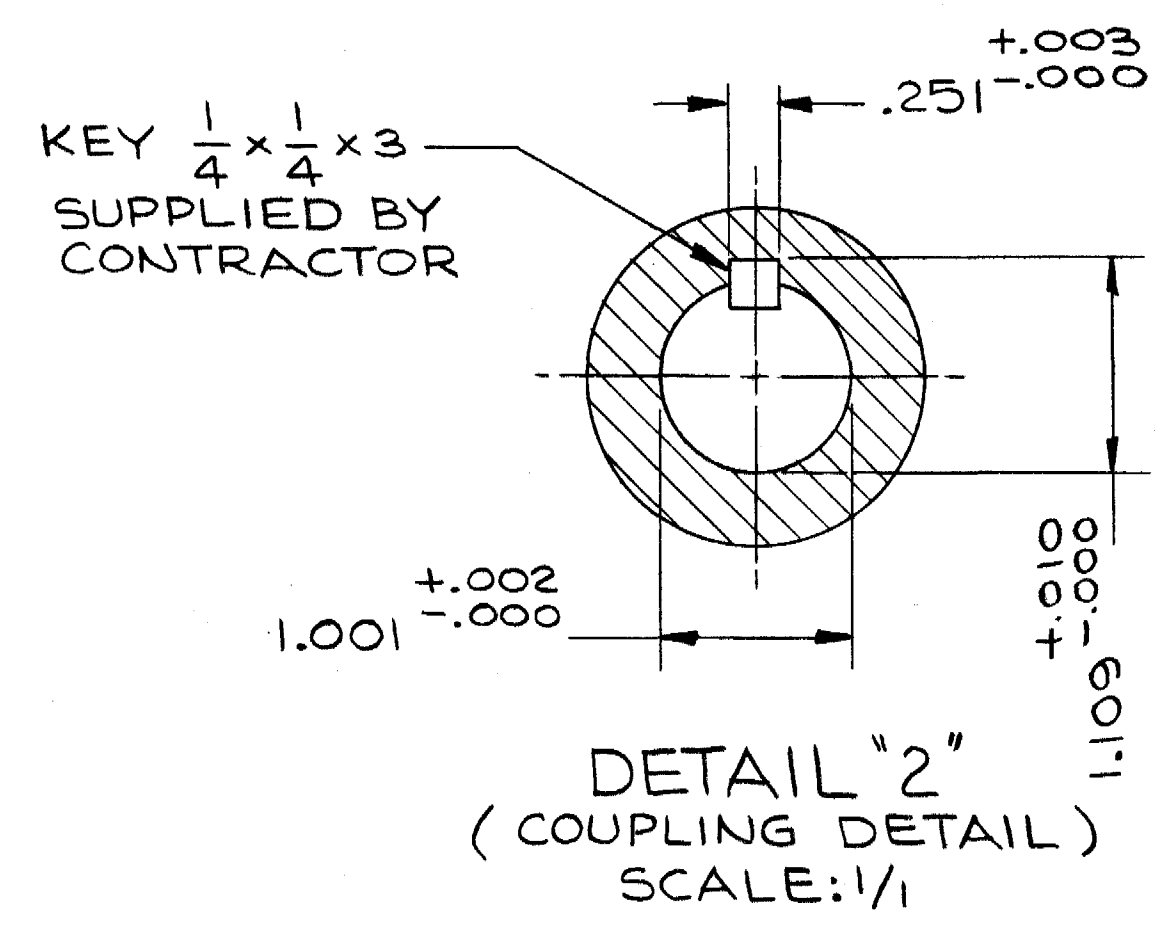
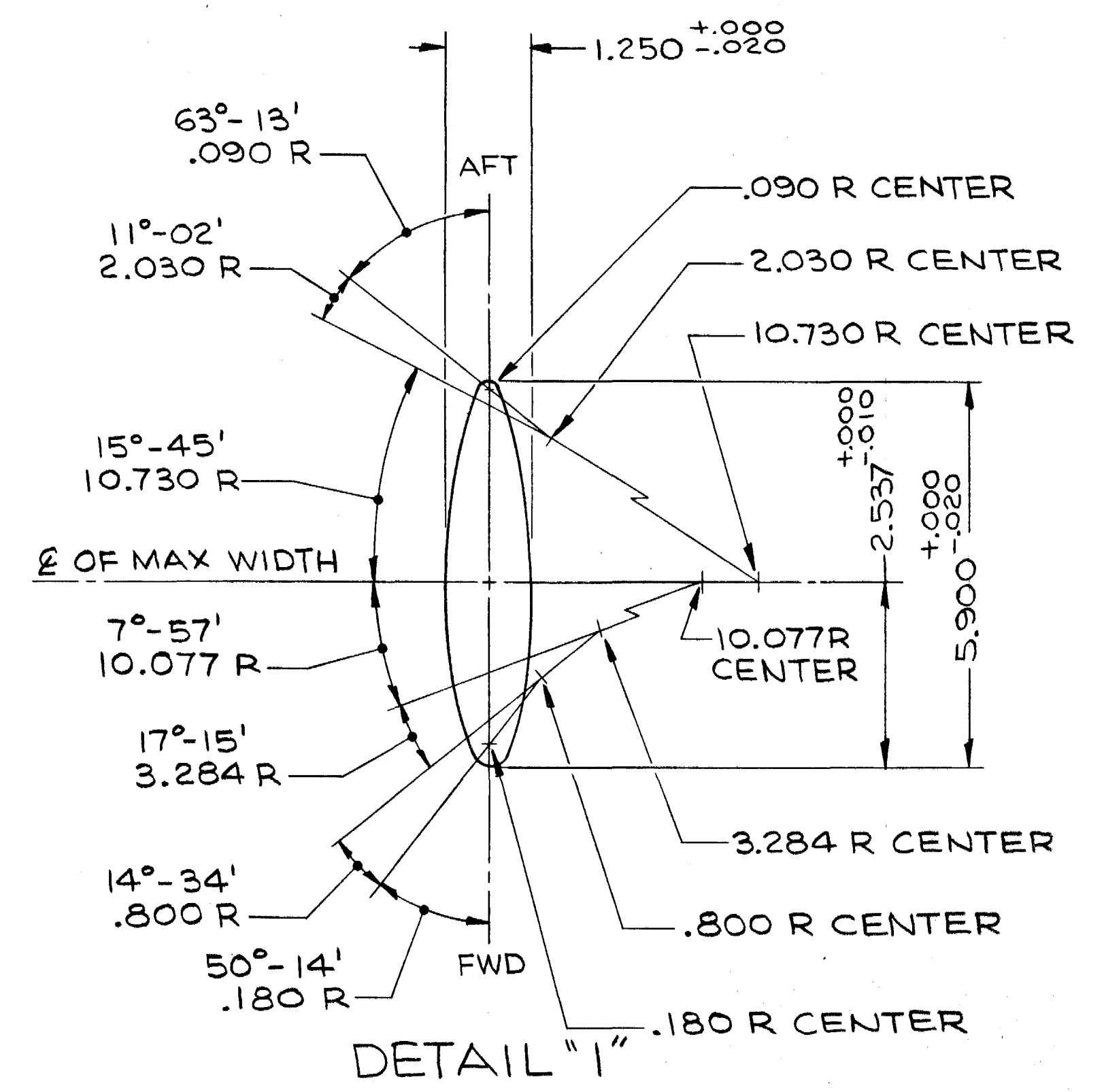

QTY REQD	SYM	NOMENCLATURE OR DESCRIPTION	CODE IDENT	PART OR IDENTIFYING NO.	SPECIFICATION	MATERIAL OR NOTE	UNIT WT	ZONE	ITEM NO.

LIST OF MATERIALS OR PARTS LIST			
UNLESS OTHERWISE SPECIFIED DIMENSIONS ARE IN INCHES TOLERANCES ON FRACTIONS DECIMALS ANGLES	DRAWING STARTED DATE	PITOMETER LOG CORP PARAMUS, N.J.	
MATERIAL:	DRAWN <i>Donna K. Banta</i> 15 AUG 74	SEA VALVE SV-(C) MK6 MOD0 EM LOG OUTLINE & INSTALLATION DRAWING	
	CHECKED	SIZE	CODE IDENT NO.
	ENGR	D	47496
50200-501 MK6MOD0(406)	FINISH:	SCALE	50225
NEXT ASSY USED ON		1/2	SHEET 2 OF 2
APPLICATION			

ULTRAVIEW PAPER

50225